



Fire Safety Policy

ECHEL FORD PRIMARY SCHOOL

Status: School Based

Date Approved: 3rd October 2025

To be reviewed: October 2026 (unless major changes to premises are made)

Introduction

The prevention of fire is of vital importance. Most fires are caused by carelessness and ignorance. It is the responsibility of all personnel to become conversant with these instructions.

Upon outbreak of fire the saving and preservation of life takes precedence over the salvaging of property. A member of staff's first duty is to look after the children and this will mean the evacuation of the building. No attempt should be made to fight the fire until their safety is ensured, and then without exposing any person to risk.

Fire Risk Assessments

It is the responsibility of the Headteacher to ensure that Fire Risk Assessments are carried out regularly, at least every three years. The Risk Assessments can be carried out either by a Health and Safety sub-committee, likely to be made up of 1 governor, a designated fire warden, a member of Senior Leadership team and the Site Manager or this duty can be outsourced to an accredited Fire Risk Assessment company.

If any material changes are made to the structure or layout of the buildings a new Risk Assessment should be carried out immediately.

Staff Training

All staff are expected to complete the annual online fire safety training as well as familiarising themselves with the evacuation procedures for the area of the building they are in at the time. All this information is kept updated in the Echelford Fire Evacuation Policy.

Visitors

Visitors will be instructed as to the evacuation procedure as they sign in, details of evacuation procedures are also on the reverse of the visitor's badge.

Disabled Evacuation

All fire exits are wide enough to enable wheelchair users to leave the building easily and safely. Risk assessments will be carried out on all disabled people to ensure safe evacuation and a Personal Evacuation Plan will be drawn up.

Fire Drills

Fire drills will be carried out once a term at different times of the day. This will include a simulated evacuation drill. When a fire drill is held it will be recorded in the fire logbook. These will take place at different times of the day and also will include 'blocked routes' which will need staff to consider alternative routes.

Testing of Fire Alarm System

The fire alarm system will be tested weekly by the Site Manager. Each alarm point will be numbered and a different number will be tested each week and recorded in the logbook.

The Fire Alarm system is inspected annually by an accredited external company and clear records kept. All Fire Extinguishers will also be inspected annually and details noted on the Fire Extinguishers.

Fire call points are located in all classrooms, corridors and shared areas in both bases. These are checked as part of the Risk Assessment process detailed above.

Emergency Exits

All emergency exits are to be kept clear and free from obstruction at all times.

General Fire Safety

All staff will make it their responsibility to ensure:

- Their exit doors are unlocked when the first person arrives. Generally, all doors are unlocked by the Site Manager before staff arrive. Fire doors will not be propped open
- Please make sure that anything hanging on your classroom door will not impede its closure in the case of fire and that there is nothing on the floor that will do so either.
- There is 1 metre clearance to the routes of exit doors
- Combustible materials (paper, card, fabrics etc) are not stored near to sockets or lights
- Unnecessary lights or electrical appliances (Computers, printers, TVs, fans, laminators, toasters, etc) are to be switched off and if practical unplugged.
- All electrical items, plugs and cables are checked each year in PAT testing
- If you bring in any of your own electrical item e.g., mobile phone charger, you must have it PAT tested by the caretaker before using
- You are fully aware of your exit routes as this may differ from class to class
- You sign in or out whenever you enter or leave the building. Failure to do either can mean either no-one will look for you if you do not make it out of the building or others may remain looking for you, putting themselves in danger.

Smoking

Smoking and vaping is prohibited in or around the school.

ADVICE ON THE PROCEDURE IN THE EVENT OF A FIRE

Key Roles

The office staff are responsible for ensuring that all documentation is collected that identifies who is currently in the building at the time of the fire, essential medication and the Emergency Plan. The office will also call 999 to report the fire so please ensure any pertinent information is sent there as soon as possible.

Class teachers must check that their class area is clear (in the teacher's absence this duty will fall to the TA) of children.

Teaching assistants will check the nearest toilets, vacated classrooms, PPA rooms, offices and communal areas for any children.

SLT (out of class) / HSLW/ ELSA – will check areas on the floor they are on to ensure that all spaces are vacated.

Discovering a fire

1. If you discover a fire operate the nearest fire alarm call point by pushing the glass firmly.
2. If you hear the fire alarm, evacuate the premises immediately through the nearest fire exit as detailed in the evacuation procedure for the base.
3. A member of office staff to dial 999 to report incident.

On hearing fire alarm

1. Classroom doors will close automatically (this is why it is vital that there is nothing to impede these). Close all other doors once the room has been checked (if possible).
2. Proceed to your assembly point where registers will be handed out by the office staff. Please ask your children to repeat their name back and ensure you have seen the child too. To verify all your children are in attendance, please do a head count.

The office staff will also take the late book to account for any children that were late to school. Once agreed hold the Register in the air to signify all adults and children are accounted for.

3. A member of office staff will check the visitor book and ensure all visitors are accounted for.
4. A member of office staff will take the Fire Evacuation Routine and Record book to hand to emergency services. This includes floor plan of building.
5. All urgent medication should be taken by the Welfare Office/office staff e.g., Auto injectors, diabetic, severe asthma.
6. Class Teachers will be given the class lists. No pupil must be marked present unless seen by that teacher.

After the event

1. Do not re-enter the building until advised to do so by the senior fire service officer or by the senior member of staff on base.
2. If the fire has been extinguished by staff, do not disturb any evidence which could indicate the cause of the fire.
3. Ensure that the premises are in safe working order before reoccupying.
4. Take all class children back into their rooms for a final head count and explanation of what has happened before they return to normal activities.

Know: -

1. Your means of escape, primary and secondary
2. The nearest fire alarm point
3. The nearest fire appliance and how it should be used
4. The assembly point (if you are in a different room, please check on the list by the door)

SAFE EVACUATION PROCEDURES

The member of office staff will call 999 to report the incident.

Classrooms

All children will be escorted from the classrooms via the closest fire exit. Please refer to plan at the end of the policy. The children will then be led by the support staff (if in) to the Assembly point in the KS1 playground. Teachers and any additional staff must check that all rooms close to them are cleared of children and close doors, if able.

The office staff will ensure the offices, adult toilets, kitchen and hall are evacuated safely, closing doors and windows as appropriate and then proceed to assembly point with registers.

If a small group of children are out of class engaged in focused work with an adult, they will exit through the nearest door to re-join their class at the assembly point.

External classrooms – please cross the KS2 playground and make your way around the outside of the building to the KS1 playground.

Library – exit through the door at the end of the corridor, by the boy's toilet

Lighthouse/Nest - exit through the door at the end of the corridor, by the boy's toilet

Dining Hall – staff to lead children via the nearest, clearest exit.

1. The KS1 corridor – straight down the corridor and out onto KS1 playground
2. The exit door between the KS2 lunch trolleys - To open these doors, please turn the lock and then press the green exit button. Please make your way to the KS1 playground
3. The corridor between the ASC and the dining hall – only use if the other 2 exits are in use. Please make your way around the outside of the building to the KS1 playground.

Gym – there are 2 fire exits. One at the far-right corner which leads onto the KS2 playground, if exiting this way, please make your way to the KS1 playground via the outside of the building or the main gym doors - exit through the door at the end of the corridor, by the boy's toilet.

Main Hall – there are 4 fire exits. Please choose the most appropriate given the number of children in the hall at the time and the possible location of the fire.

1. Through the server room at the back of the hall – this will bring you out to the reception outside area, please make your way to the KS1 playground.
2. Main hall door by the lunch trolleys – please exit and then turn right out of the Fire Exit doors leading to the reception play area. To open these doors, please turn the lock and then press the green exit button.
3. Side doors in the hall - exit through the door at the end of the corridor, by the boy's toilet

Breakfast Club and After School Club – please walk straight ahead and out the doors by the lunch trolleys. To open these doors, please turn the lock and then press the green exit button. Please make your way to the KS1 playground.

Kitchen staff will exit out to the small staff car park. They have a key to the gates so they can move through the KS2 playground, around the back of the school and congregate at the KS1 playground with the rest of the school staff.

IN THE EVENT OF A REAL EMERGENCY, NOT A DRILL, THE SENIOR LEADERS WOULD LEAD THE CHILDREN AND STAFF TO MEADHURST SCHOOL WHERE PARENTS WOULD BE CONTACTED AS SOON AS POSSIBLE. DEPENDING ON WHERE THE SEAT OF THE FIRE IS, THE ROUTE WILL BE EITHER VIA THE STAFF CAR PARK / KS2 PLAYGROUND GATES / KS1 PLAYGROUND GATES, UP PARK ROAD AND THEN LEFT ALONG FELTHAM HILL ROAD.

A nominated person or caretaker will wait to meet the emergency services but will not re- enter the building until declared safe.

Lunchtime and Playtime Evacuation

Children will potentially be on the playground and in the dinner hall / hall. For the hall / dining hall, please refer to the exit points above. The children on the KS2 playground / field will be led by the staff on duty around the outside of the building to the KS1 Assembly point.

Senior member of staff and office staff will ensure that all inside areas are evacuated before leaving the building. They will be met by the class teachers and TA's and assembled in classes.

Procedures will then follow as above.

Breakfast Club and After School Club Evacuation

Children will potentially be on the playground or in the ASC/BSC club or dining hall. If the Fire alarm sounds, please make your way to the KS2 playground. This is because there are fewer numbers and you being there will alert staff arriving at the school to remain outside.

Senior member of staff and office staff will ensure that all inside areas are evacuated before leaving the building.

Wraparound care staff will ensure paper register is taken to assembly point

Procedures will then follow as above.

Fire Evacuation Plan Layout

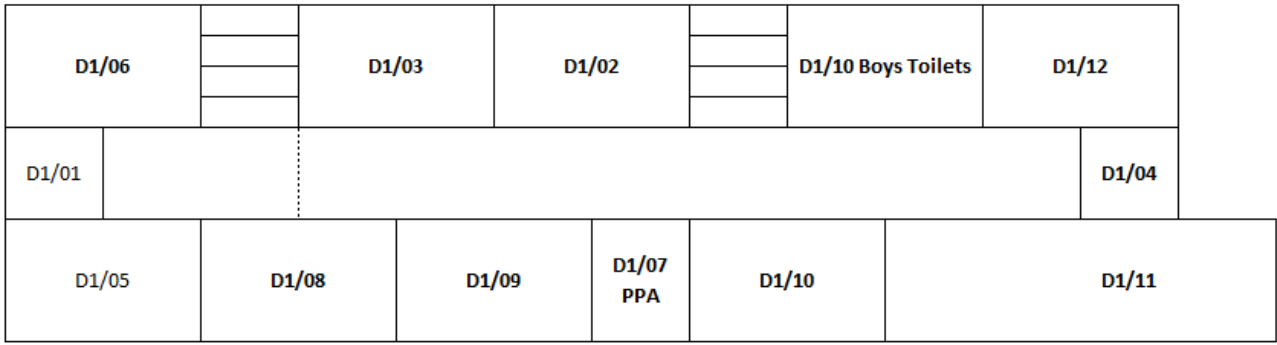

First Floor

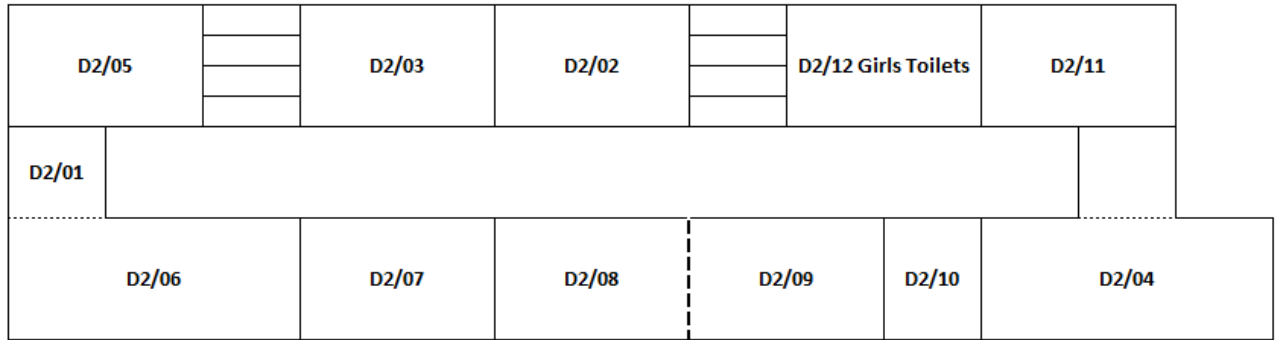

Second Floor

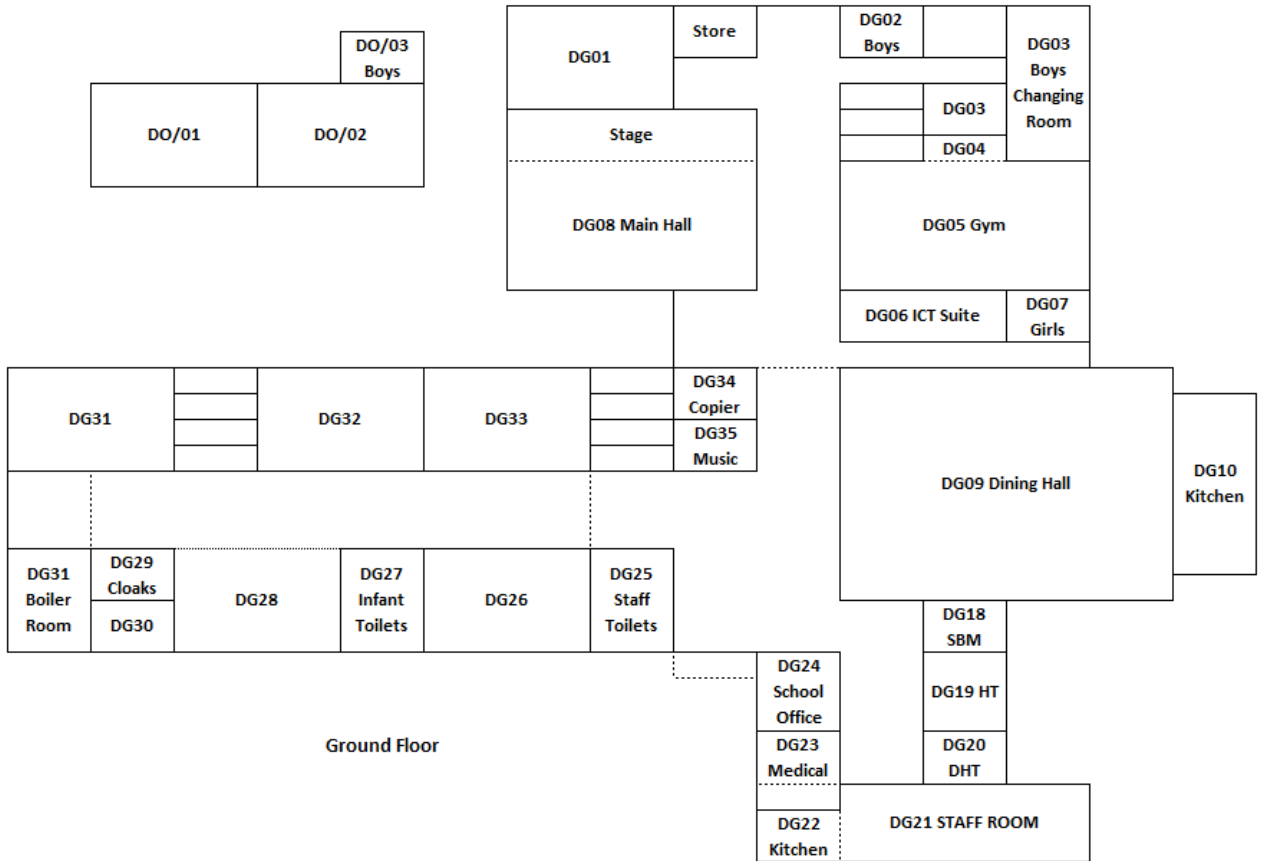

Ground Floor